

23

Ray Optics

Note: Please use a ruler or straight edge for drawing light rays.

23.1 The Ray Model of Light

1. If you turn on your car headlights during the day, the road ahead of you doesn't appear to get brighter. Why not?
- _____

2. a. Draw four or five rays from the object that allow A to see the object.
b. Draw four or five rays from the object that allow B to see the object.



A

C



B

- c. Describe the situations seen by A and B if a piece of cardboard is lowered at point C.
- _____

3. a. Draw four or five rays from object 1 that allow A to see object 1.
b. Draw four or five rays from object 2 that allow B to see object 2.
c. What happens to the light where the rays cross in the center of the picture?
- _____

1 ✨



B

2 ✨



A

4. A point source of light illuminates a slit in an opaque barrier.

a. On the screen, sketch the pattern of light that you expect to see. Let the white of the paper represent light areas; shade dark areas. Mark any relevant dimensions.

b. What will happen to the pattern of light on the screen if the slit width is reduced to 0.5 cm?

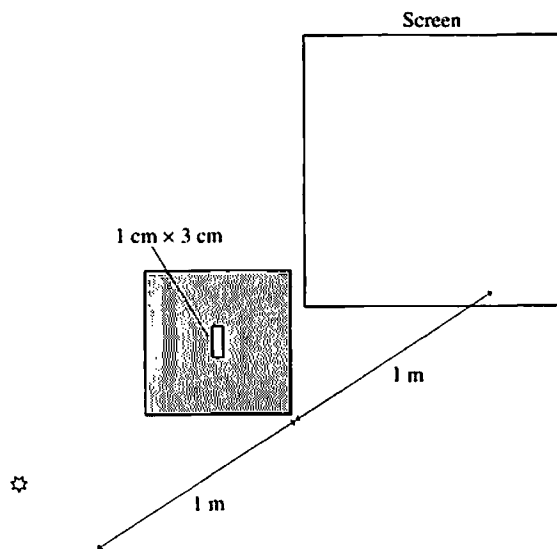

5. In each situation below, light passes through a 1-cm-diameter hole and is viewed on a screen. For each, sketch the pattern of light that you expect to see on the screen. Let the white of the paper represent light areas; shade dark areas.

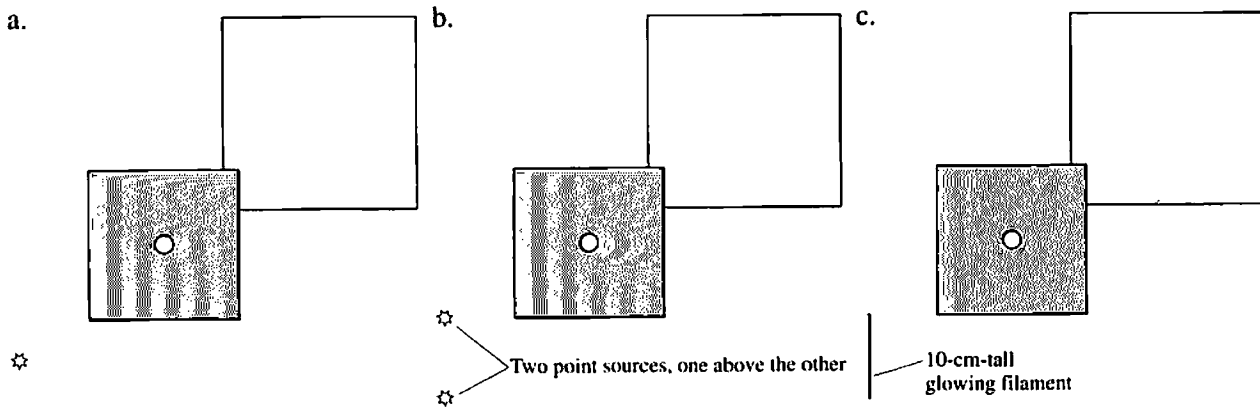

6. Light from a bulb passes through a pinhole. On the screen, sketch the pattern of light that you expect to see.

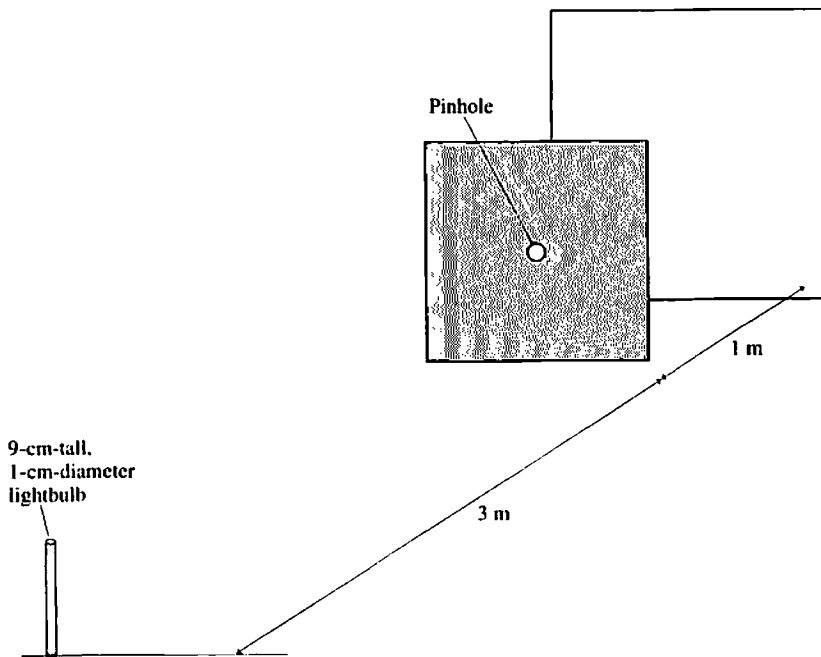

23.2 Reflection

7. a. Draw five rays from the object that pass through points A to E after reflecting from the mirror. Make use of the grid to do this accurately.
- b. Extend the reflected rays behind the mirror.
- c. Show and label the image point.

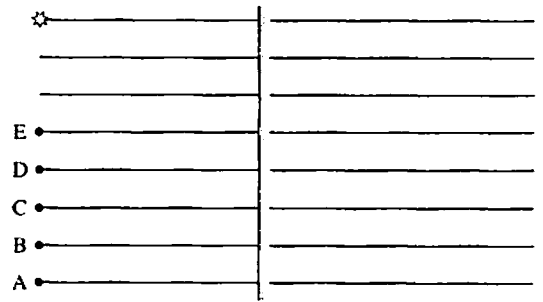

8. a. Draw *one* ray from the object that enters the eye after reflecting from the mirror.
- b. Is one ray sufficient to tell your eye/brain where the image is located?

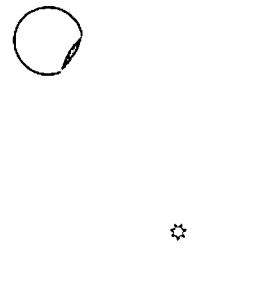

- c. Use a different color pen or pencil to draw two more rays that enter the eye after reflecting. Then use the three rays to locate (and label) the image point.
- d. Do any of the rays that enter the eye actually pass through the image point?

9. You are looking at the image of a pencil in a mirror.
 - a. What happens to the image you see if the top half of the mirror, down to the midpoint, is covered with a piece of cardboard? Explain.

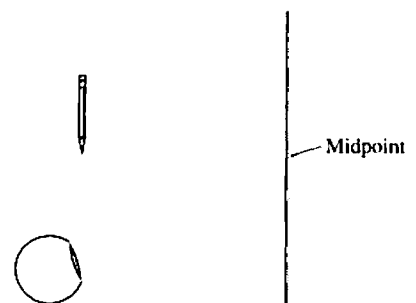

- b. What happens to the image you see if the bottom half of the mirror is covered with a piece of cardboard? Explain.

10. The two mirrors are perpendicular to each other.

- a. Use a ruler to draw a ray directly from the object to point A. Then draw two rays that strike the mirror about 3 mm (1/8 in) on either side of A. Draw the reflections of these three rays, making sure each obeys the law of reflections, then extend the reflections either forward or backward to locate an image point.

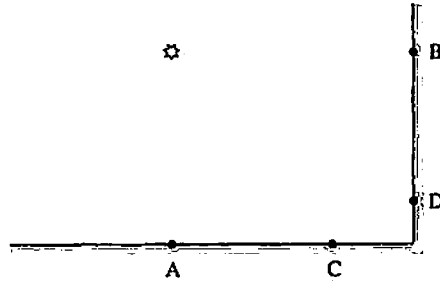

- b. Do the same for points B, C, and D.
 c. How many images are there, and where are they located?

A large empty rectangular box provided for the student to draw ray diagrams and answer the questions.

23.3 Refraction

11. Draw seven rays from the object that refract after passing through the seven dots on the boundary.

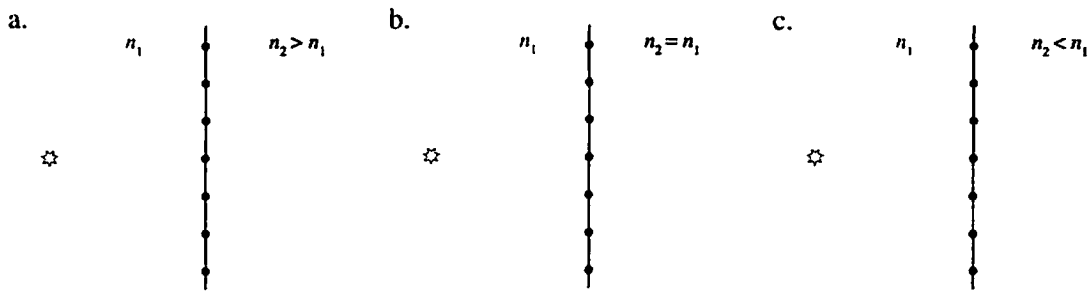

12. Complete the trajectories of these three rays through material 2 and back into material 1. Assume $n_2 < n_1$.

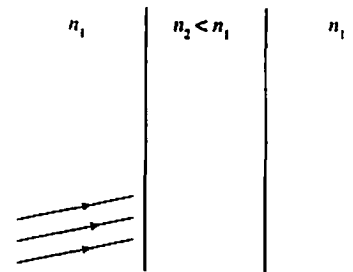

13. The figure shows six conceivable trajectories of light rays leaving an object. Which, if any, of these trajectories are impossible? For each that is possible, what are the requirements of the index of refraction n_2 ?

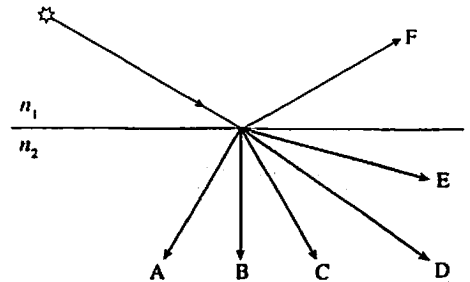

- Impossible _____
- Requires $n_2 > n_1$ _____
- Requires $n_2 = n_1$ _____
- Requires $n_2 < n_1$ _____
- Possible for any n_2 _____

14. Complete the ray trajectories through the two prisms shown below.

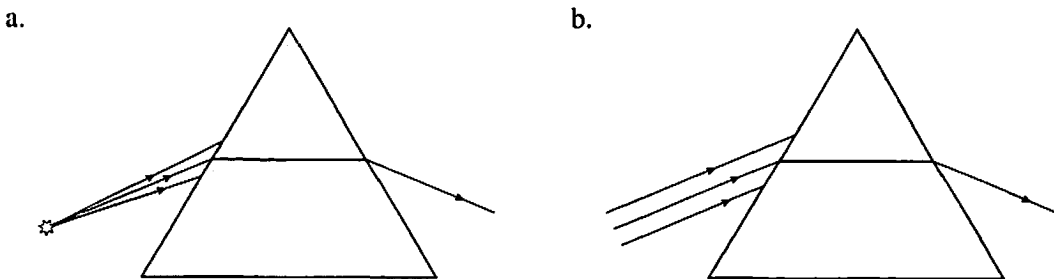

15. Draw the trajectories of seven rays that leave the object heading toward the seven dots on the boundary. Assume $n_2 < n_1$ and $\theta_c = 45^\circ$.

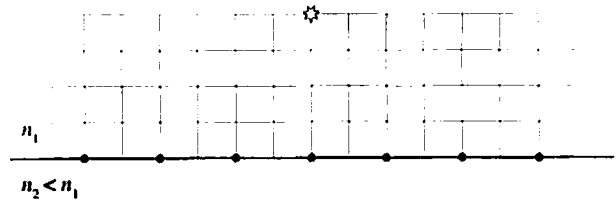

23.4 Image Formation by Refraction

16. a. Draw rays that refract after passing through points B, C, and D. Assume $n_2 > n_1$.

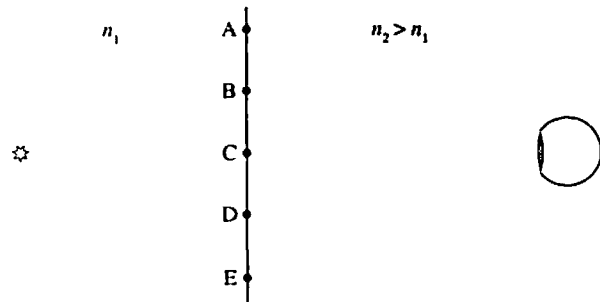

- b. Use dashed lines to extend these rays backward into medium 1. Locate and label the image point.
- c. Now draw the rays that refract at A and E.
- d. Use a different color pen or pencil to draw three rays from the object that enter the eye.
- e. Does the distance to the object *appear* to be larger than, smaller than, or the same as the true distance? Explain.

17. A thermometer is partially submerged in an aquarium. The underwater part of the thermometer is not shown.
- a. As you look at the thermometer, does the underwater part appear to be closer than, farther than, or the same distance as the top of the thermometer?

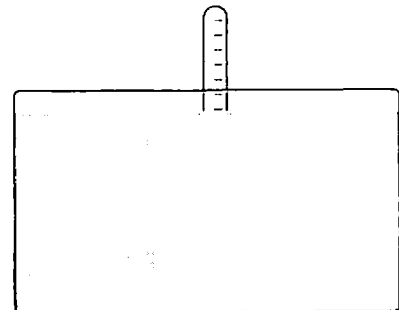

- b. Complete the drawing by drawing the bottom of the thermometer as you think it would look.

23.5 Color and Dispersion

18. A beam of white light from a flashlight passes through a red piece of plastic.

a. What is the color of the light that emerges from the plastic?

b. Is the emerging light as intense as, more intense than, or less intense than the white light?

c. The light then passes through a blue piece of plastic. Describe the color and intensity of the light that emerges.

19. Suppose you looked at the sky on a clear day through pieces of red and blue plastic oriented as shown. Describe the color and brightness of the light coming through sections 1, 2, and 3.

Section 1: _____

Section 2: _____

Section 3: _____

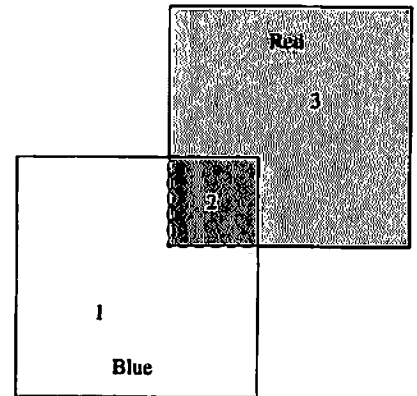

20. Sketch a plausible absorption spectrum for a patch of bright red paint.

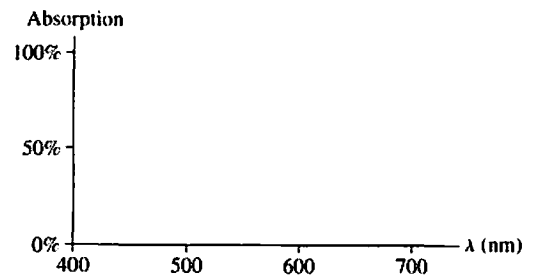

21. Sketch a plausible absorption spectrum for a piece of green plastic.

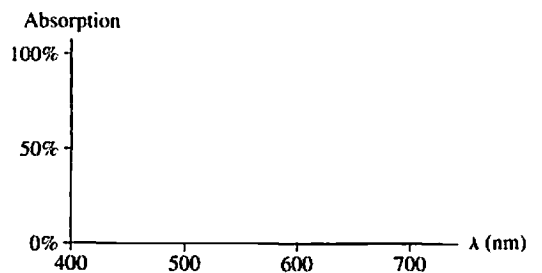

23.6 Thin Lenses: Ray Tracing

22. a. Continue these rays through the lens and out the right side.

b. Is the point where the rays converge the same as the focal point of the lens? Or different? Explain.

c. Place a point source of light at the place where the rays converged in part b. Draw several rays heading left, toward the lens. Continue the rays through the lens and out the left side.

d. Do these rays converge? If so, where?

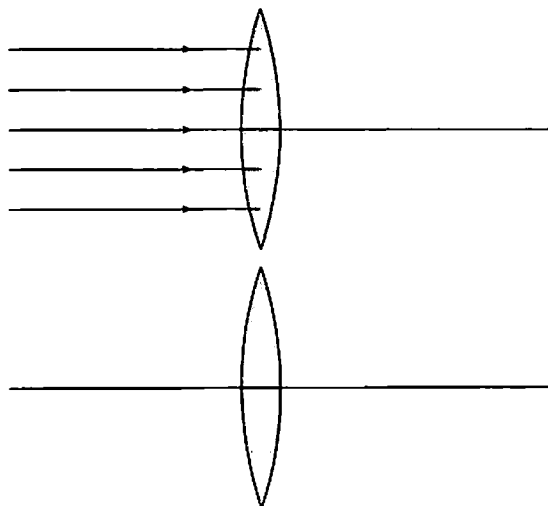

23. The top two figures show test data for a lens. The third figure shows a point source near this lens and four rays heading toward the lens.

a. For which of these rays do you know, from the test data, its direction after passing through the lens?

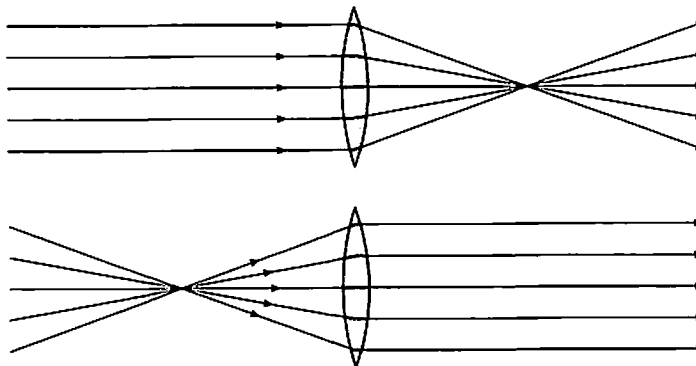

b. Draw the rays you identified in part a as they pass through the lens and out the other side.

c. Use a different color pen or pencil to draw the trajectories of the other rays.

d. Label the image point. What kind of image is this?

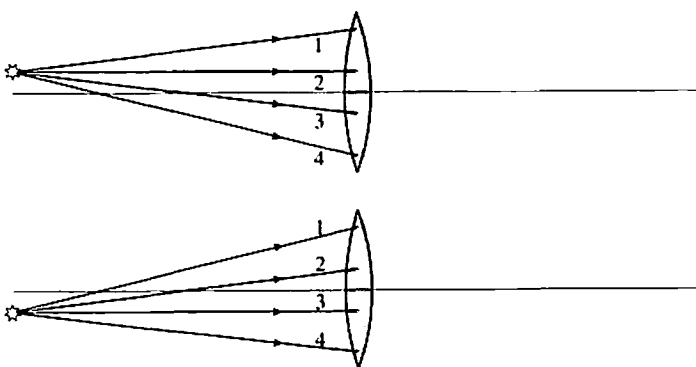

e. The fourth figure shows a second point source. Use ray tracing to locate its image point.

f. The fifth figure shows an extended object. Have you learned enough to locate its image? If so, draw it.

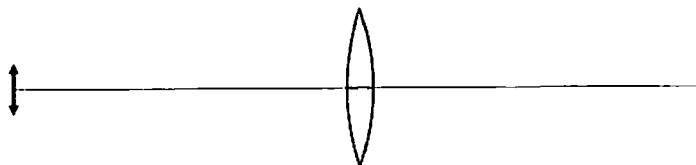

24. An object is near a lens whose focal points are marked with dots.

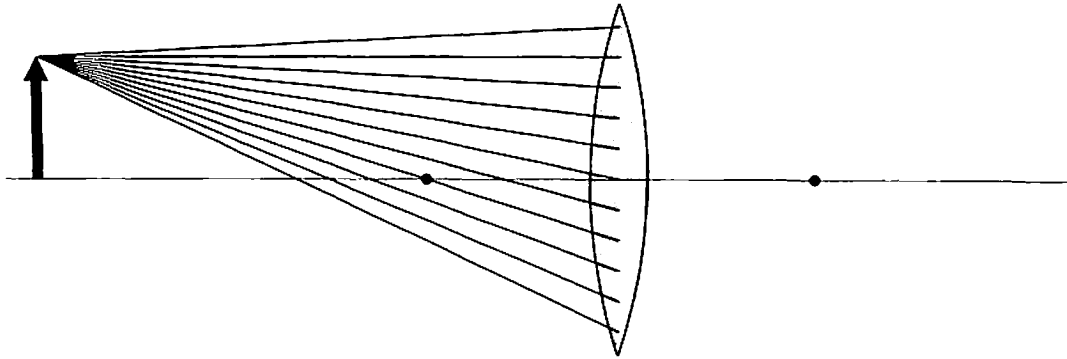

- a. Identify the three special rays and continue them through the lens.
 - b. Use a different color pen or pencil to draw the trajectories of the other rays.
25. a. Consider *one* point on an object near a lens. What is the minimum number of rays needed to locate its image point?

- b. For each point on the object, how many rays from this point actually strike the lens and refract to the image point?

26. An object and lens are positioned to form a well-focused, inverted image on a viewing screen. Then a piece of cardboard is lowered just in front of the lens to cover the *top half* of the lens. Describe what happens to the image on the screen. What will you see when the cardboard is in place?

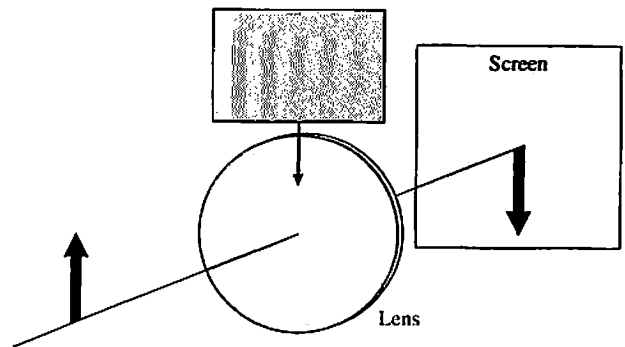

27. An object is near a lens whose focal points are shown.
- Use ray tracing to locate the image of this object.
 - Is the image upright or inverted?

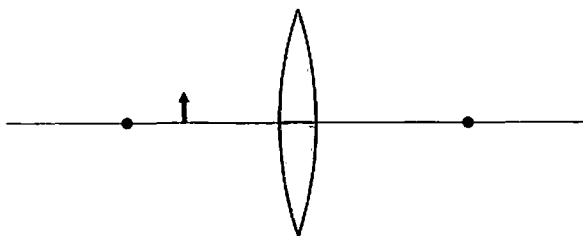

- Is the image height larger or smaller than the object height?

- Is this a real or a virtual image? Explain how you can tell.

28. The top two figures show test data for a lens. The third figure shows a point source near this lens and four rays heading toward the lens.

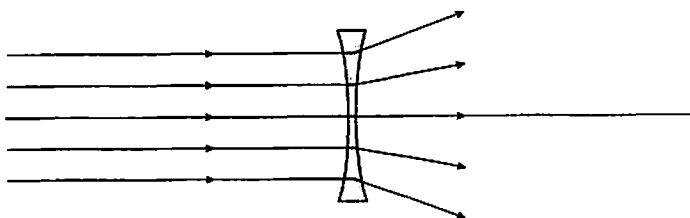

- For which of these rays do you know, from the test data, its direction after passing through the lens?

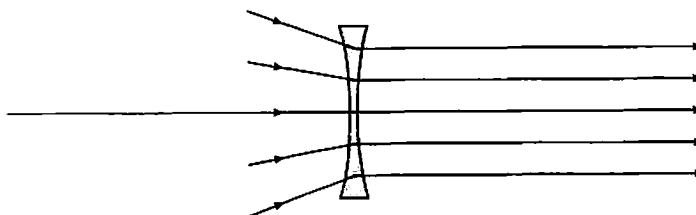

- Draw the rays you identified in part a as they pass through the lens and out the other side.

- Use a different color pen or pencil to draw the trajectories of the other rays.

- Find and label the image point. What kind of image is this?

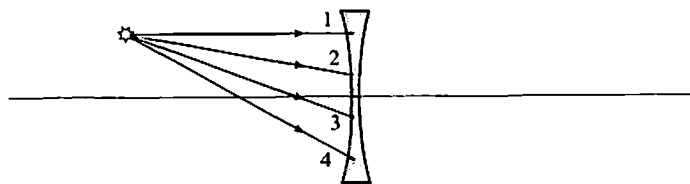

23.7 Thin Lenses: Refraction Theory

29. Materials 1 and 2 are separated by a spherical surface. For each part:
- Draw the normal to the surface at the seven dots on the boundary.
 - Draw the trajectories of seven rays from the object that pass through the seven dots.
 - Trace the refracted rays either forward to a point where they converge or backward to a point from which they appear to diverge.

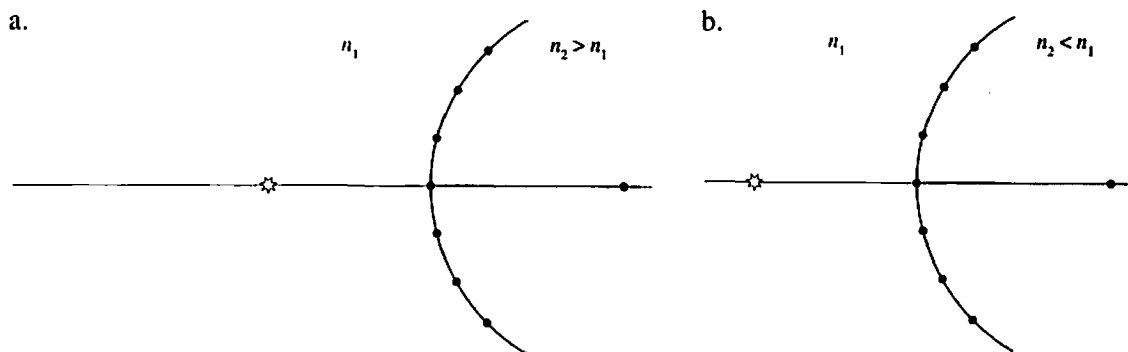

30. A converging lens forms a real image. Suppose the object is moved farther from the lens. Does the image move toward or away from the lens? Explain.

31. A converging lens forms a virtual image. Suppose the object is moved closer to the lens. Does the image move toward or away from the lens? Explain.

23.8 Image Formation with Spherical Mirrors

32. Two spherical mirrors are shown. The center of each is marked. For each:

- i. Draw the normal to the surface at the seven dots on the boundary.
- ii. Draw the trajectories of seven rays that strike the mirror surface at the dots and then reflect, obeying the law of reflection.
- iii. Trace the reflected rays either forward to a point where they converge or backward to a point from which they diverge.

a.

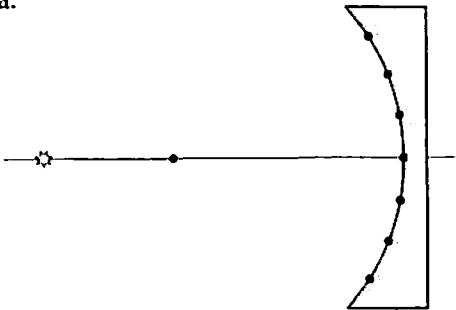

b.

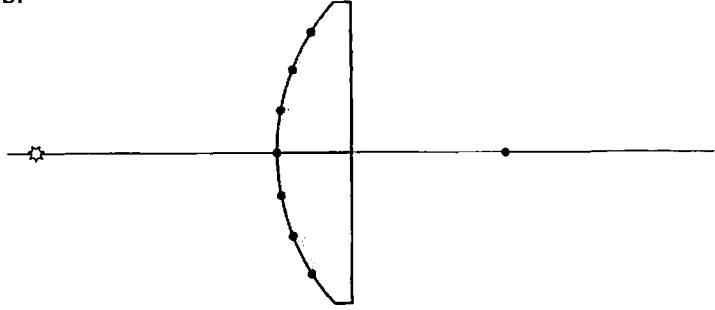

33. An object is placed near a spherical mirror whose focal point is marked.

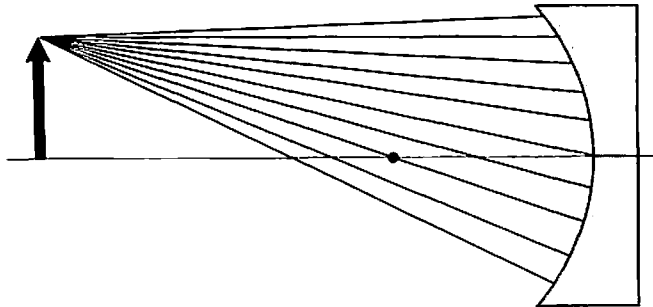

- a. Identify the three special rays and show their reflections.
- b. Use a different color pen or pencil to draw the trajectories of the other rays.