

## York U. PHYS 1420 (F19): WRITTEN HW Assignment #2

Purpose: Obtain experience (and graded feedback) w/ regard to clearly writing out solutions to relevant problems

- You are expected to do all problems and write out clear/coherent solutions for such
- You will be graded based upon a spot-check for completeness & 2-3 problems will be chosen at random and graded thoroughly
- To get full credit, your solutions must lay out a legible and clearly-explained (e.g., step-by-step) path, all the way from assumptions made to the final (boxed) answer
- Solutions will be posted after the specified due date. Late submissions will be accepted as per the Lateness Policy spelled out in the syllabus

## Problem 1

A grindstone has a constant angular acceleration  $\alpha$  of 3.0 radians/sec<sup>2</sup>. Starting from rest a line, such as  $OP$  in Fig. 11-5, is horizontal. Find (a) the angular displacement of the line  $OP$  (and hence of the grindstone) and (b) the angular speed of the grindstone 2.0 sec later.

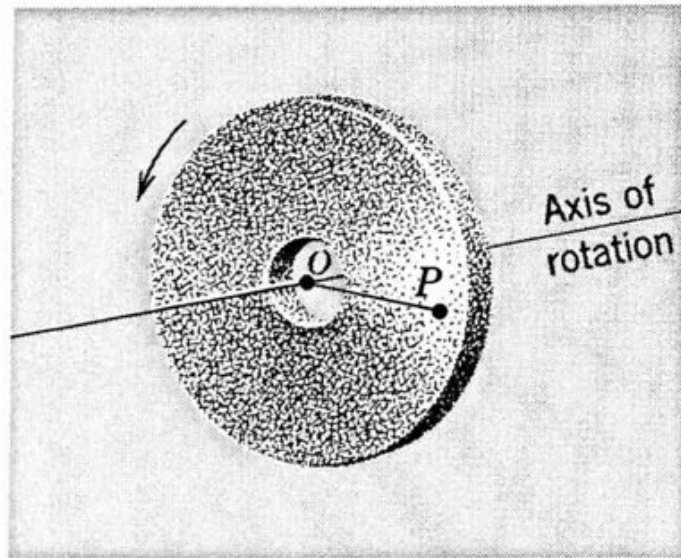
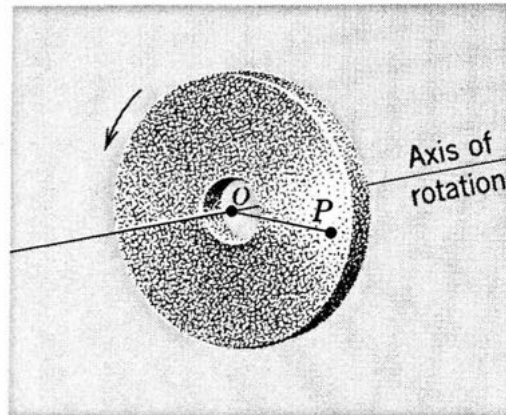

**Fig. 11-5** Example 1. The line  $OP$  is attached to a grindstone rotating as shown about an axis through  $O$  that is fixed in the reference frame of the observer.

## Problem 2

If the radius of the grindstone of Example 1 is 0.50 meter, calculate (a) the linear or tangential speed of a particle on the rim, (b) the tangential acceleration of a particle on the rim, and (c) the centripetal acceleration of a particle on the rim, at the end of 2.0 sec.

(d) Are the results the same for a particle halfway in from the rim, that is, at  $r = 0.25$  meter?



**Fig. 11-5** Example 1. The line  $OP$  is attached to a grindstone rotating as shown about an axis through  $O$  that is fixed in the reference frame of the observer.

### Problem 3

A disk spins on a horizontal shaft mounted in bearings, with an angular speed  $\omega_1$  of 100 radians/sec as in Fig. 11-8*a*. The entire disk and shaft assembly are placed on a turntable rotating about a vertical axis at  $\omega_2 = 30.0$  radians/sec, counterclockwise as we view it from above. Describe the rotation of the disk as seen by an observer in the room.

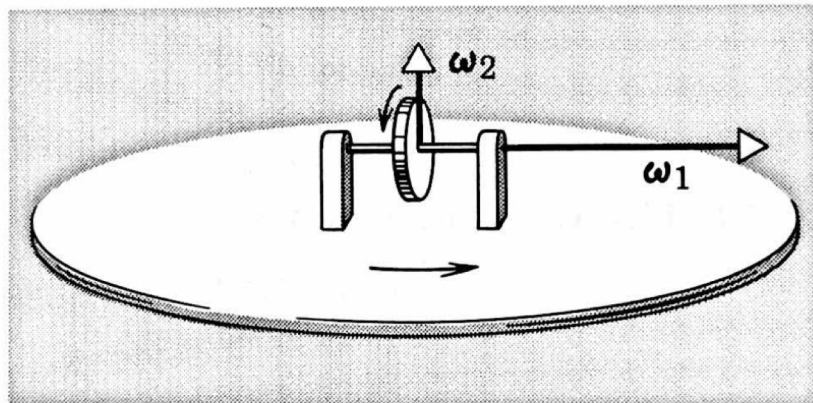

(a)

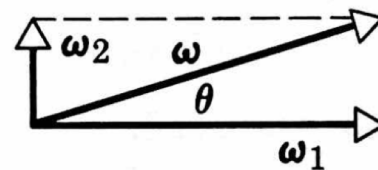

(b)

## Problem 4

A uniform disk of radius  $R$  and mass  $M$  is mounted on an axle supported in fixed frictionless bearings, as in Fig. 12-12. A light cord is wrapped around the rim of the wheel and a steady downward pull  $\mathbf{T}$  is exerted on the cord. Find the angular acceleration of the wheel and the tangential acceleration of a point on the rim.

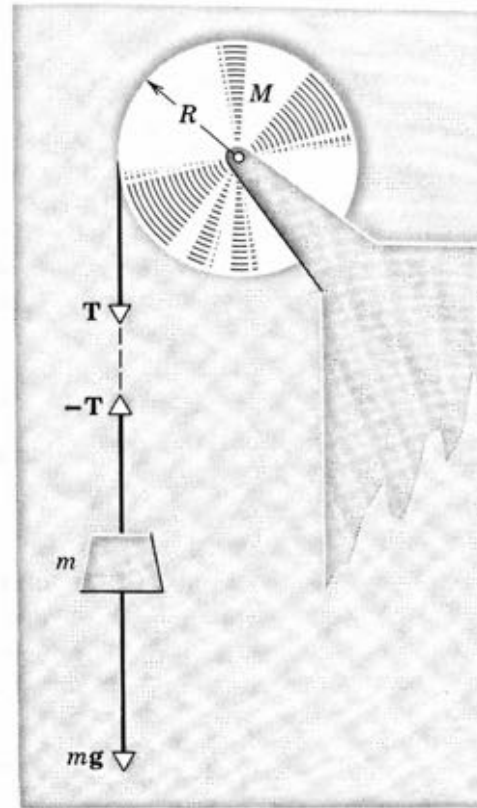

**Fig. 12-12** Example 4. A steady downward force  $\mathbf{T}$  produces rotation of the disk. Example 5. Here  $\mathbf{T}$  is supplied by the falling mass  $m$ .

## Problem 5

Suppose that we hang a body of mass  $m$  from the cord in the previous problem. Find the angular acceleration of the disk and the tangential acceleration of a point on the rim in this case.

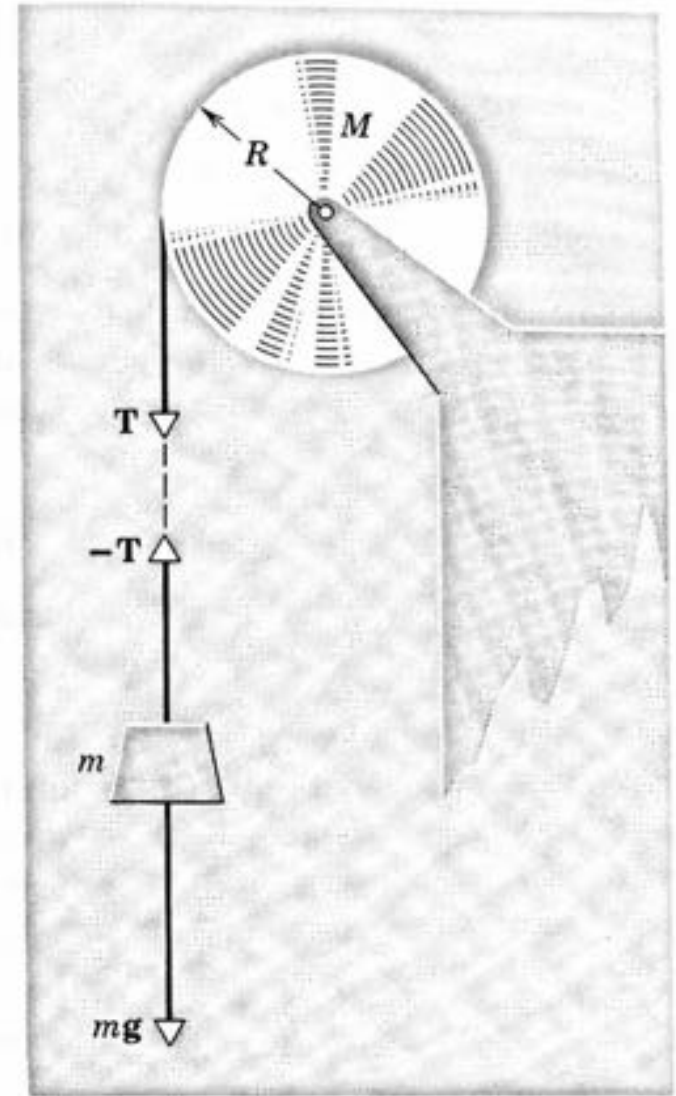

**Fig. 12-12** Example 4. A steady downward force  $T$  produces rotation of the disk. Example 5. Here  $T$  is supplied by the falling mass  $m$ .

## Problem 6

A heavy wooden plank is placed so one-third of its length protrudes from the side of a pirate ship. The plank has a total length of 12[m] and a total weight of 120[kg]. How far onto the plank can a person weighing 100[kg] walk before the plank tips into the ocean?

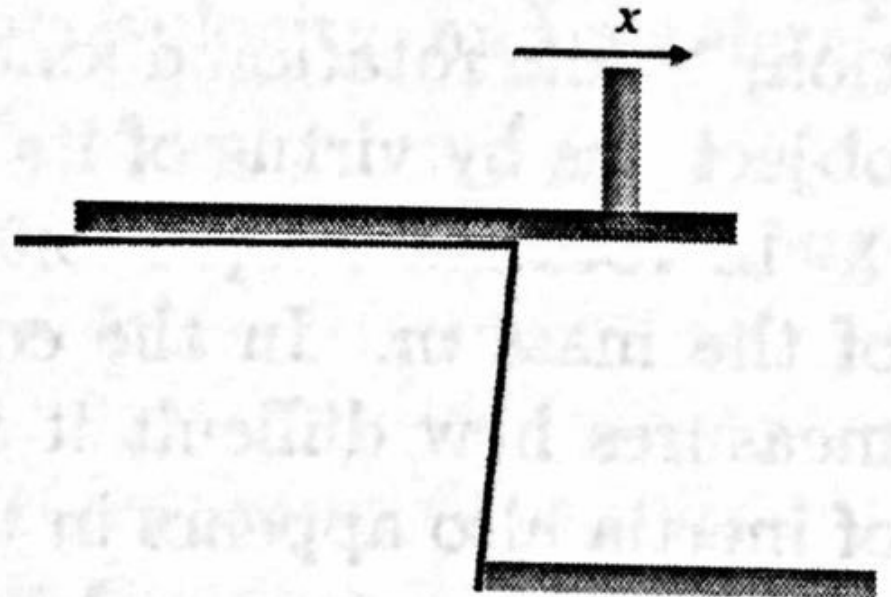

## Problem 7

|| A 100 g block on a frictionless table is firmly attached to one end of a spring with  $k = 20 \text{ N/m}$ . The other end of the spring is anchored to the wall. A 20 g ball is thrown horizontally toward the block with a speed of 5.0 m/s.

- a. If the collision is perfectly elastic, what is the ball's speed immediately after the collision?
- b. What is the maximum compression of the spring?
- c. Repeat parts a and b for the case of a perfectly inelastic collision.



## Problem 8

A 20-cm-diameter, 2.0 kg solid disk is rotating at 200 rpm. A 20-cm-diameter, 1.0 kg circular loop is dropped straight down onto the rotating disk. Friction causes the loop to accelerate until it is “riding” on the disk. What is the final angular velocity of the combined system?

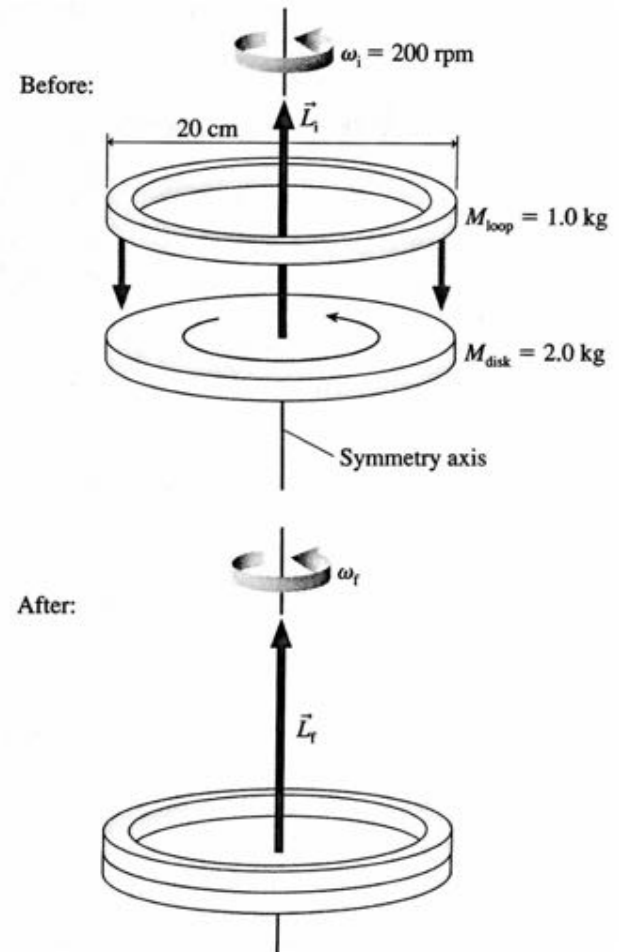

## Problem 9

- || An athlete at the gym holds a 3.0 kg steel ball in his hand. His arm is 70 cm long and has a mass of 4.0 kg. What is the magnitude of the torque about his shoulder if he holds his arm
- Straight out to his side, parallel to the floor?
  - Straight, but  $45^\circ$  below horizontal?

## Problem 10

|| A 2.0 kg, 20-cm-diameter turntable rotates at 100 rpm on frictionless bearings. Two 500 g blocks fall from above, hit the turntable simultaneously at opposite ends of a diameter, and stick. What is the turntable's angular velocity, in rpm, just after this event?

Extra Credit

|| Your task in a science contest is to stack four identical uniform bricks, each of length  $L$ , so that the top brick is as far to the right as possible without the stack falling over. Is it possible, as **FIGURE P12.64** shows, to stack the bricks such that no part of the top brick is over the table? Answer this question by determining the maximum possible value of  $d$ .

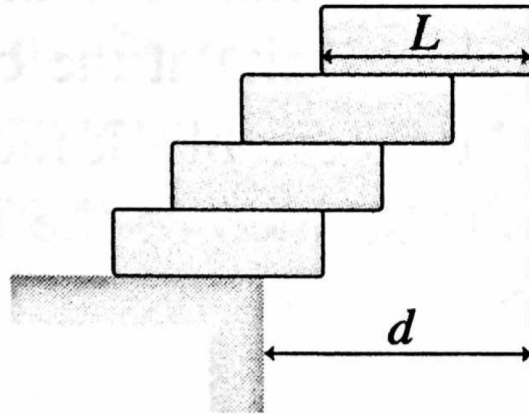

**FIGURE P12.64**