

PHYS 2010 (W20)

Classical Mechanics

2020.01.17

Tutorial

Christopher Bergevin
York University, Dept. of Physics & Astronomy
Office: Petrie 240 Lab: Farq 103
cberge@yorku.ca

Ref. (re images):
Knudsen & Hjorth (2000), Kesten &
Tauck (2012)

COUNT!

How many different triangles are there in the figure?

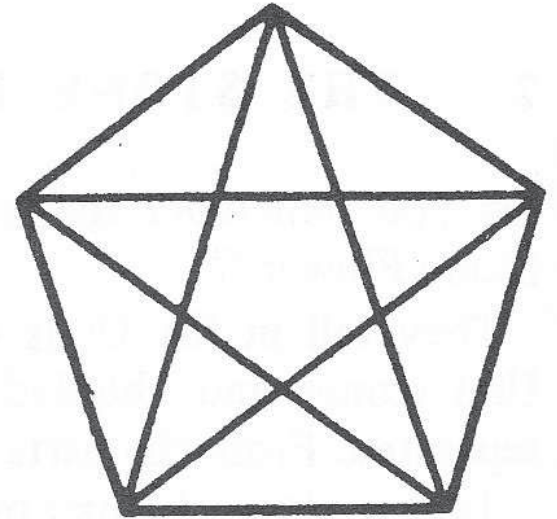

Ex.

Can a man, standing against a wall so that his right shoulder and right leg are in contact with the wall (Fig. 27), raise his left leg and in so doing not lose equilibrium?

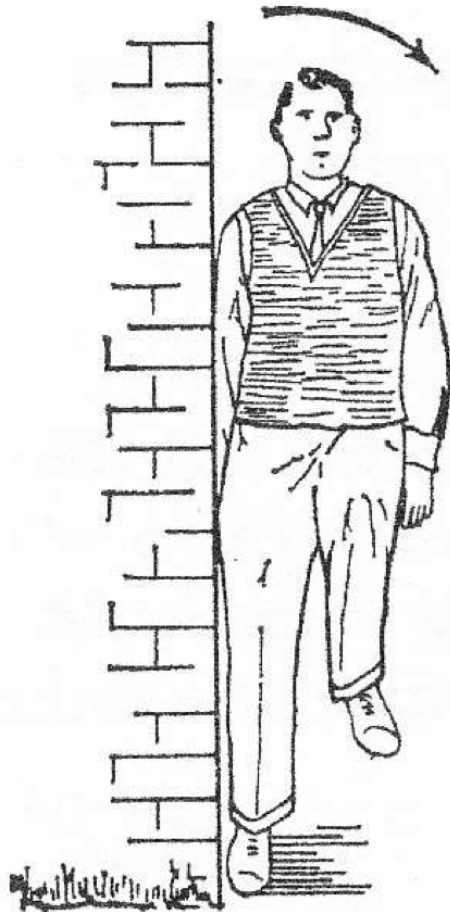
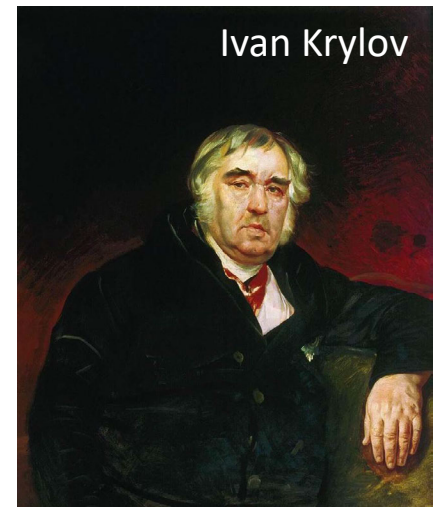

FIG. 27

Ex.

In what cases could the heroes of Krylov's famous fable, the swan, the pike and the crab, not have moved the cart in fact, assuming that they are all of equal strength and that there is no friction between cart and ground?*



* In this fable, a swan, a pike and a crab pull at a cart in three opposing directions. The cart does not move.

Ex.

A lamp hangs from a bracket whose three arms each have one end fixed in the wall, the other ends meeting at a point. The two upper arms form an isosceles triangle with an angle of

60° between the arms. The plane of this triangle is at right angles to the third arm, which makes an angle of 30° with the wall. The bulb and shade weigh 1 kg. Find the stresses in the arms (Fig. 28).

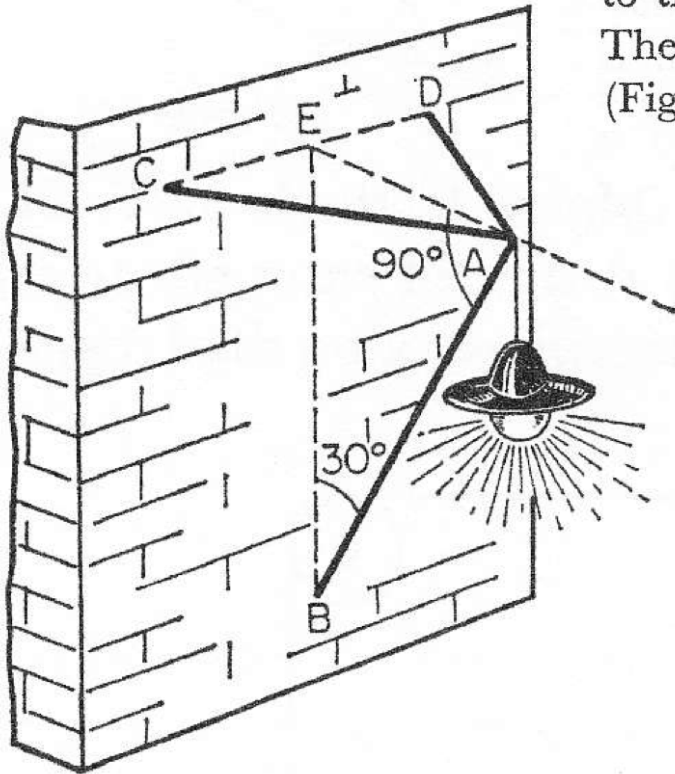

FIG. 28

Ex.

A load is attached to two strings AB and AC of equal length and suspended from them (Fig. 29). In what case will the strings break most easily, when they hang down almost vertically, or when they are stretched almost horizontally? Neglect the weight of the strings.

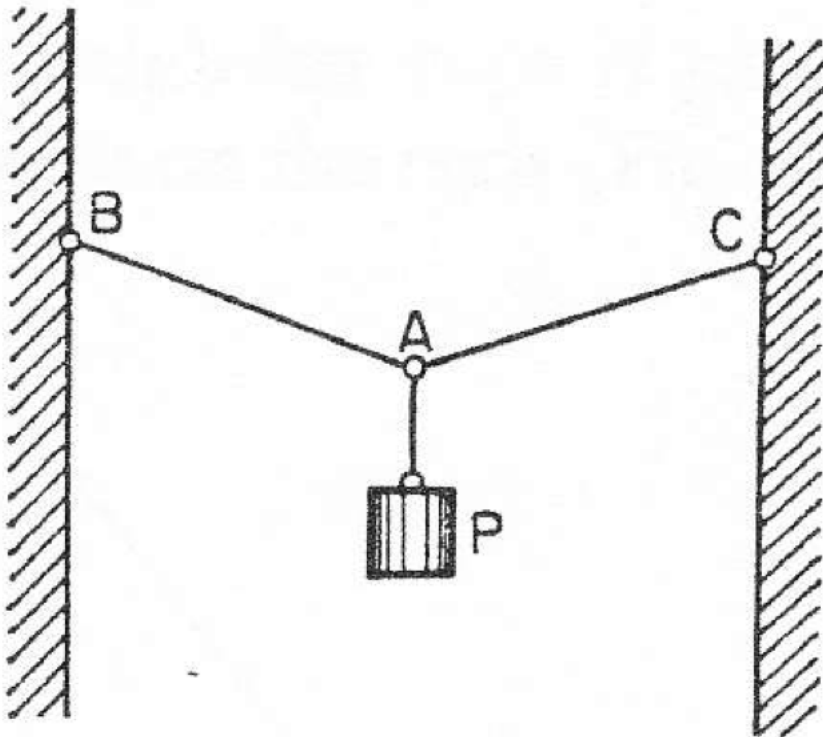

FIG. 29

Ex.

Calculate the work done in pumping oil from the cone-shaped tank in Figure 8.62 to the rim. The oil has density 800 kg/m^3 and its vertical depth is 10 m.

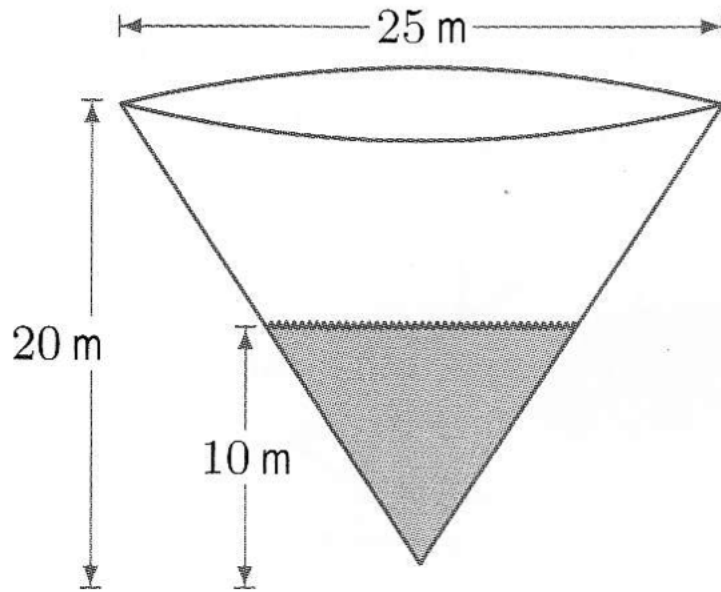
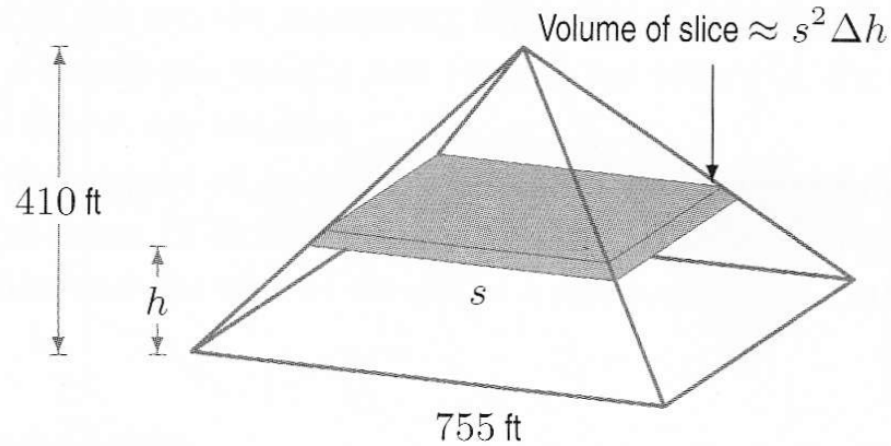

Figure 8.62: Cone-shaped tank containing oil

Ex.

It is reported that the Great Pyramid of Egypt was built in 20 years. If the stone making up the pyramid has density 200 pounds per cubic foot, find the total amount of work done in building the pyramid. The pyramid is 410 feet high and has a square base 755 feet by 755 feet. Estimate how many workers were needed to build the pyramid.



Ex.

- How does one measure the speed of a bullet?

A 10 g bullet is fired into a 1200 g wood block hanging from a 150-cm-long string. The bullet embeds itself into the block, and the block then swings out to an angle of 40° . What was the speed of the bullet? (This is called a *ballistic pendulum*.)